

REVISION HISTORY			
REV	DESCRIPTION	DATE	APPROVED

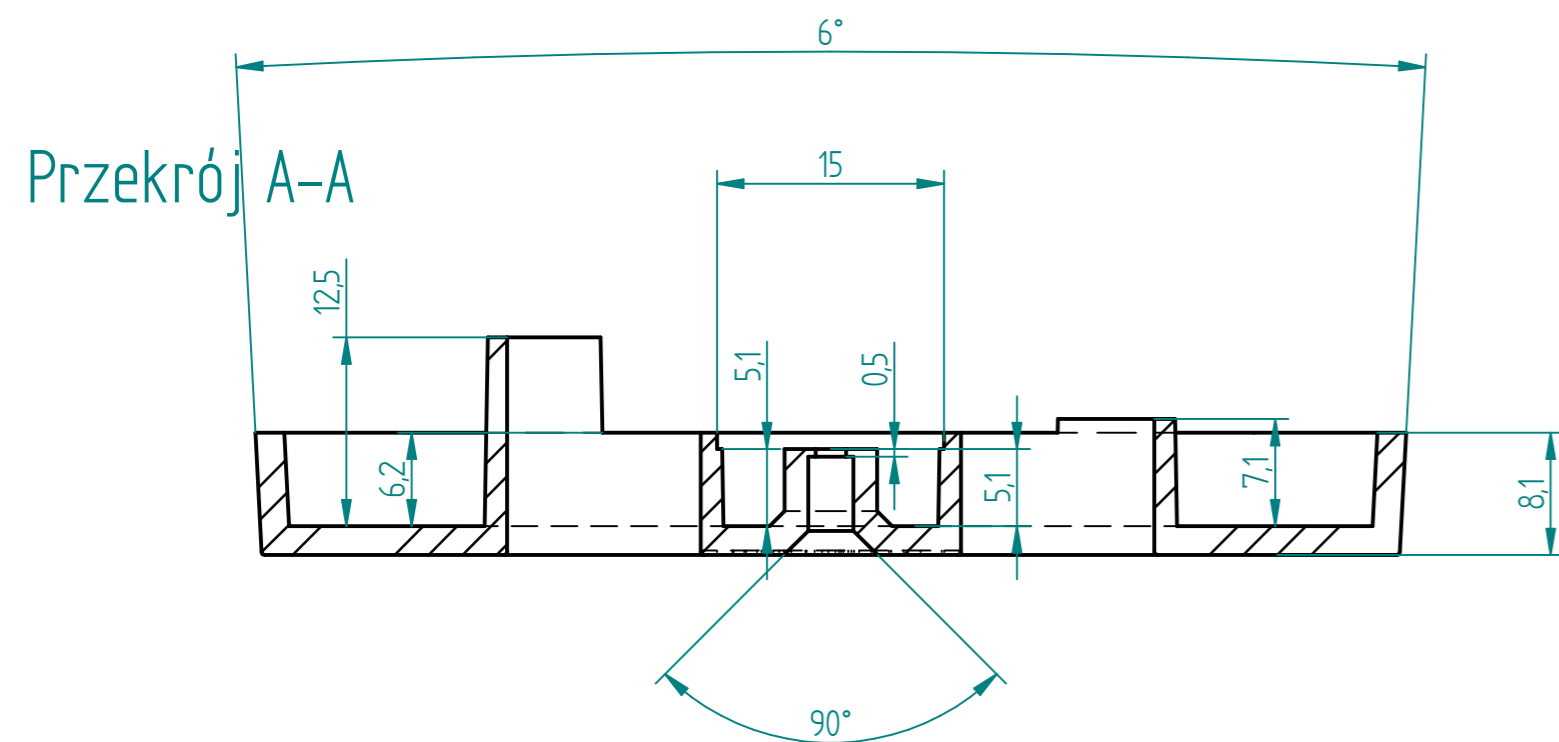

Szczegóół B

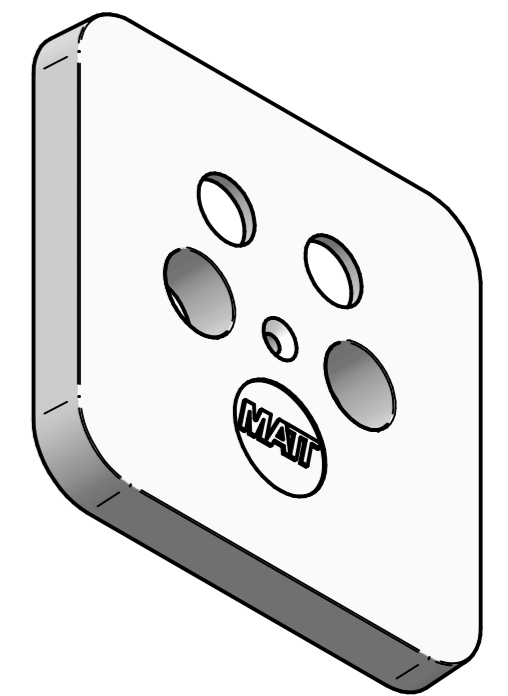
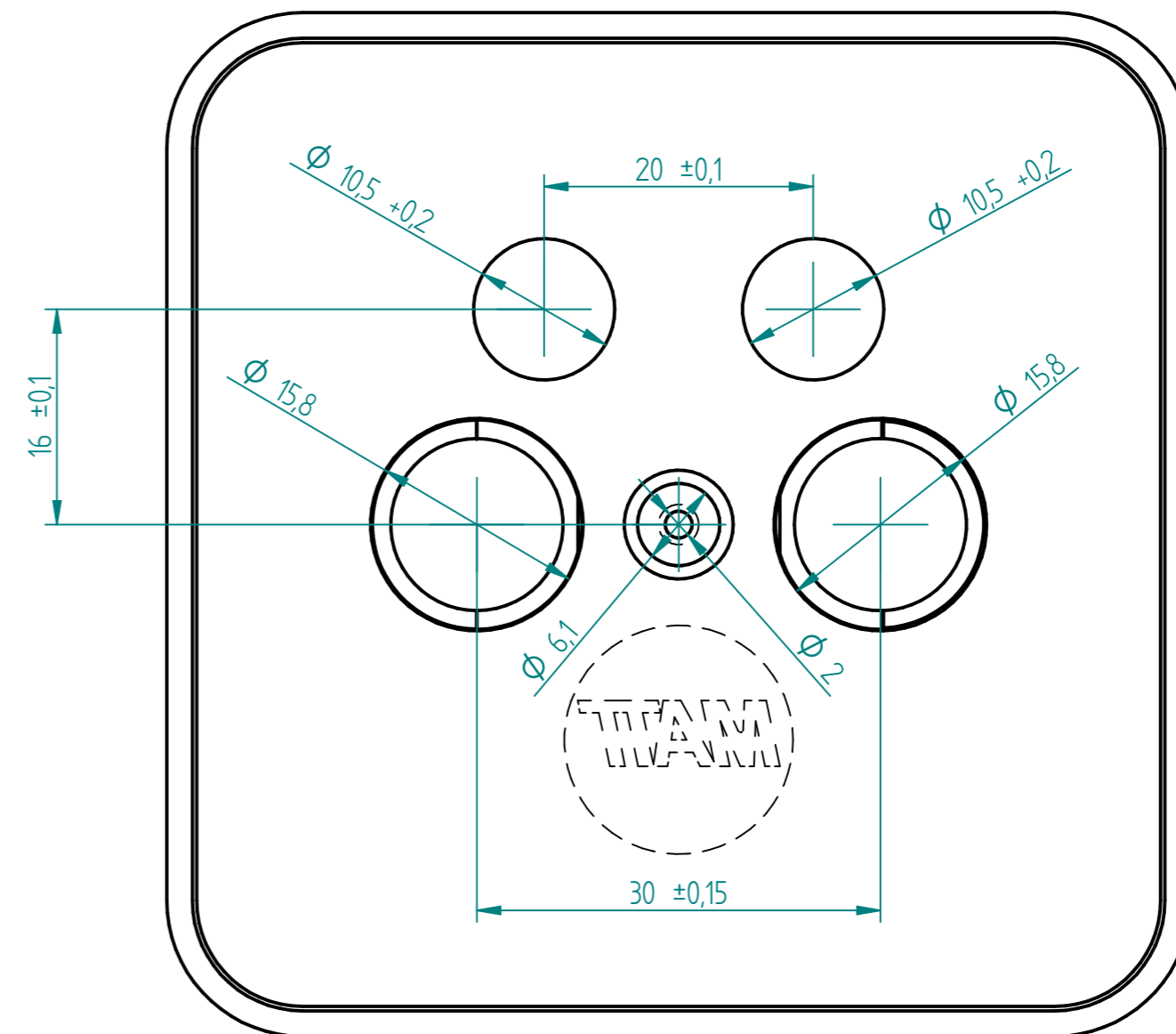
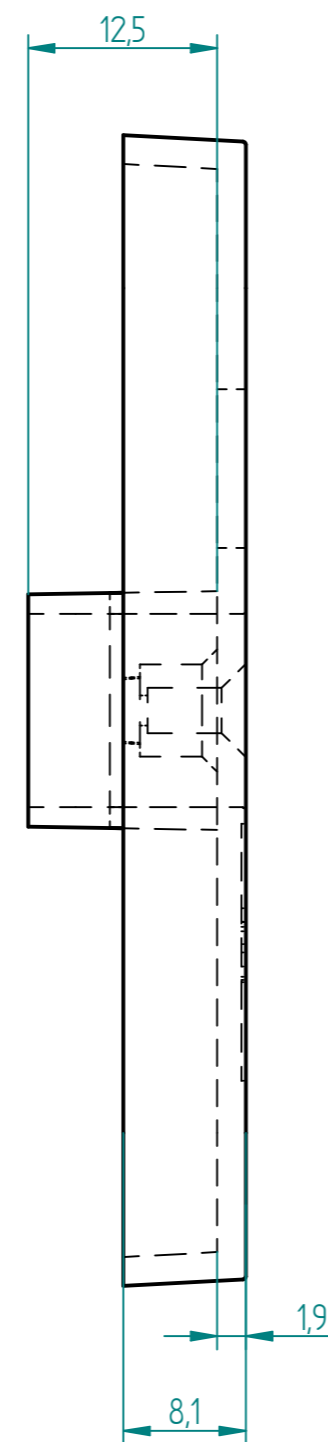
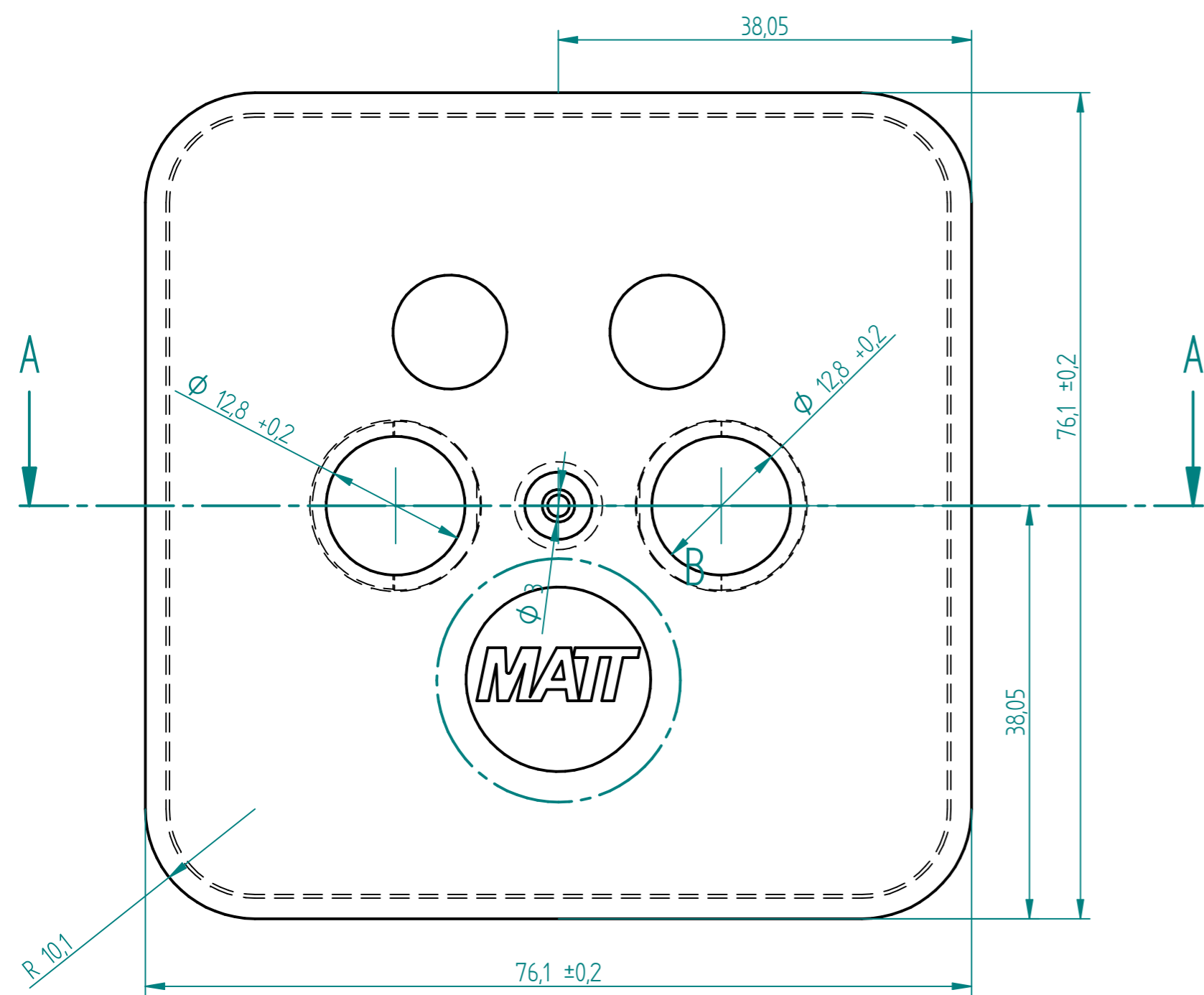
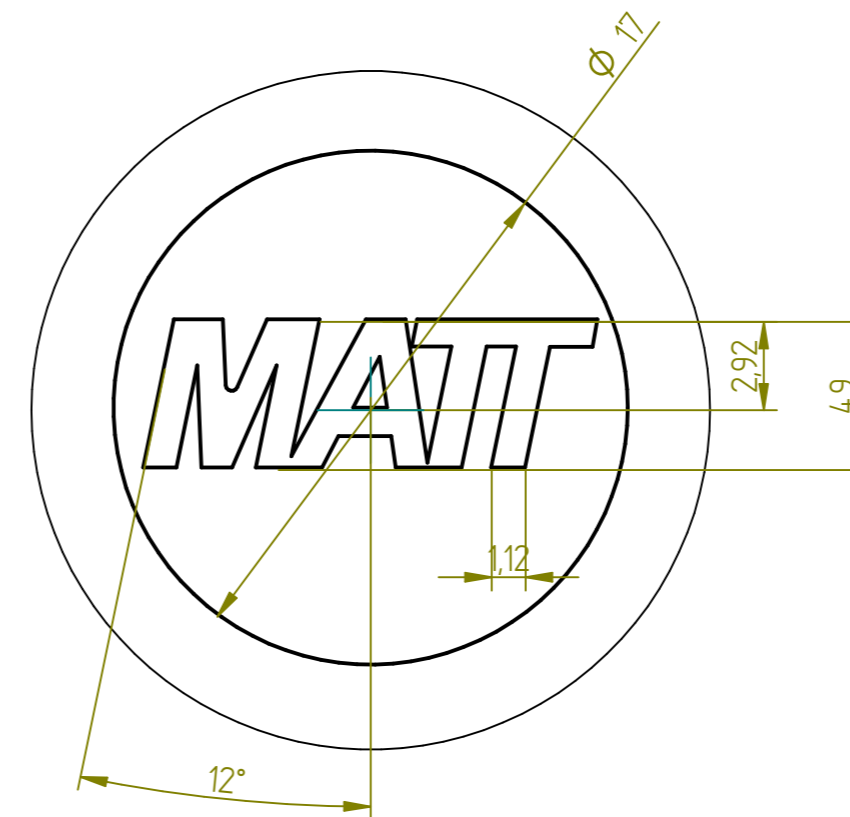

- UWAGI:
1. POWIERZCHNIA ZEWNÓTRZNA PÓŁYSK
  2. LOGO MATT WG RYSUNKU A WYBRANIE POD LOGO 0,3MM, POWIERZCHNIA MATOWA
  3. MATERIAŁ ABS
  4. POCHYLENIA TECHNOLOGICZNE 0°30'
  5. ZAOKRĄGLENIA TECHNOLOGICZNE 0,2MM

	NAME	DATE	Solid Edge	
DRAWN	Mechaniczny	06/01/11	TITLE	
CHECKED				
ENG APPR				
MGR APPR				
UNLESS OTHERWISE SPECIFIED DIMENSIONS ARE IN MILLIMETERS ANGLES ±X.X° 2 PL ±XXX 3 PL ±XXXX			SIZE A2	DWG NO 
			FILE NAME: woc8-4.dft	REV 
			SCALE:	WEIGHT:
			SHEET 1 OF 1	